

ILLUSTRATED PARTS LIST

MODEL NUMBER PSB240

PRODUCT NUMBER 961 91 00 35

MFG. ID. NUMBER 96191003500

REPAIR PARTS

AUGER HOUSING / IMPELLER ASSEMBLY

SNOW THROWER - MODEL NO. **PSB240** (96191003500), PRODUCT NO. 961 91 00 35

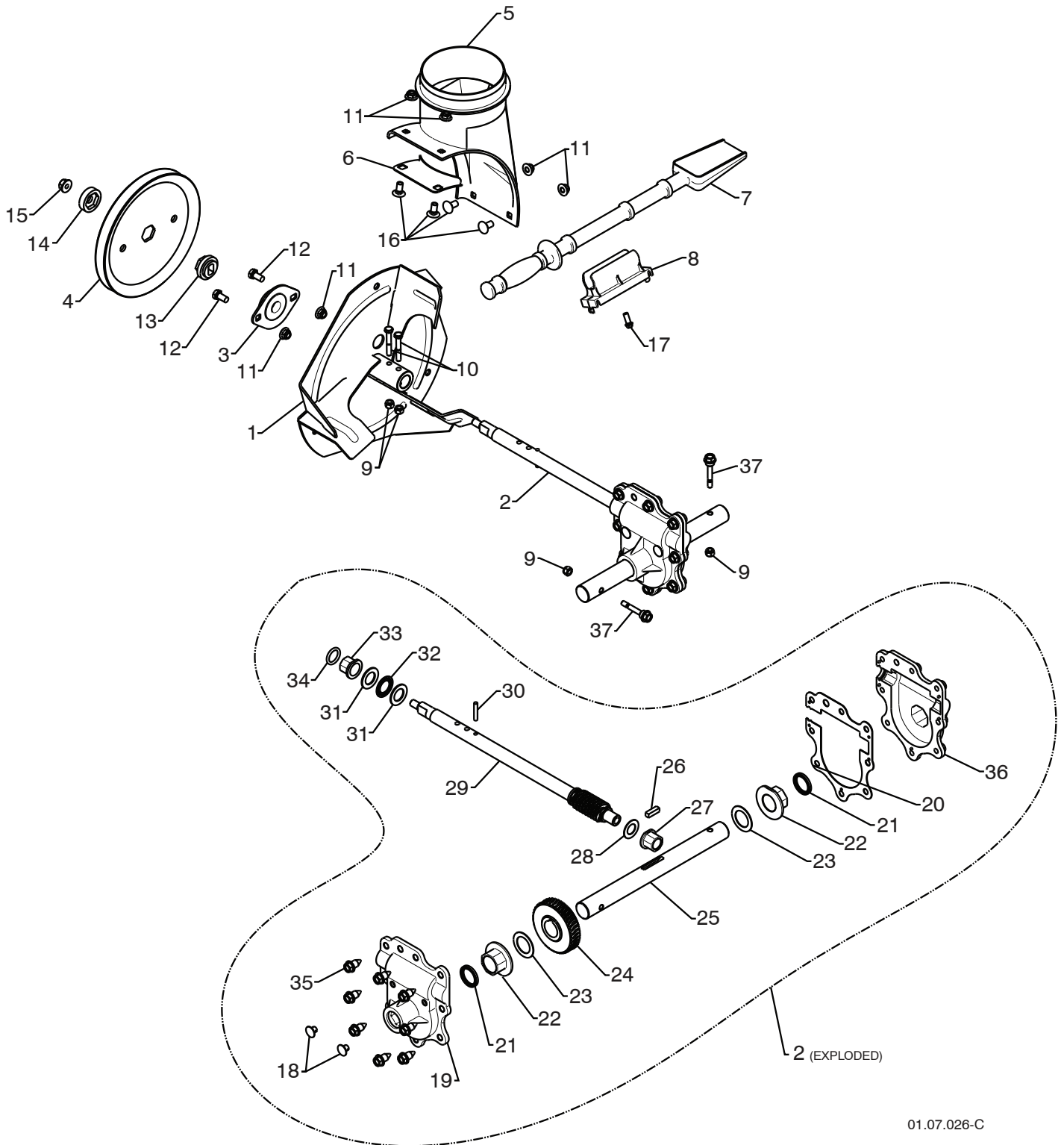

01.07.026-C

NOTE: All component dimensions given in U.S. inches. 1 inch = 25.4 mm
IMPORTANT: Use only Original Equipment Manufacturer (O.E.M.) replacement parts.
Failure to do so could be hazardous, damage your snow thrower and void your warranty.

REPAIR PARTS

AUGER HOUSING / IMPELLER ASSEMBLY

SNOW THROWER - MODEL NO. **PSB240** (96191003500), PRODUCT NO. 961 91 00 35

KEY NO.	PART NO.	DESCRIPTION
1	532 17 53-21	IMPELLER
2	532 42 71-48	GEARBOX ASSEMBLY
3	532 18 89-09	BEARING
4	532 42 71-46	IMPELLER PULLEY
5	532 17 53-22	DISCHARGE BASE
6	532 17 86-75	CORNER BRACKET
7	532 19 21-99	CLEAN OUT TOOL
8	532 40 54-00	TOOL CLIP
9	873 80 04-00	NUT 1/4-20
10	874 78 04-26	SCREW 1/4-20 X .625
11	532 42 79-42	NUT 5/16-18
12	532 16 31-83	SCREW 5/16-18 X .625
13	532 42 71-45	IMPELLER HUB
14	532 42 71-54	IMPELLER SLEEVE
15	873 90 06-00	NUT 3/8-16
16	532 18 03-55	CARRIAGE BOLT
17	532 19 41-89	SCREW 13-16 X .625
18	532 40 77-60	PLUG
19	532 42 73-02	GEARBOX COVER RH
20	532 42 73-45	GASKET
21	532 40 77-70	SEAL
22	532 40 77-62	BEARING
23	532 17 46-97	THRUST WASHER 1.00
24	532 40 77-63	WORM GEAR
25	532 40 77-64	AUGER SHAFT
26	532 18 92-82	SQUARE KEY
27	532 40 77-58	BEARING
28	532 17 46-83	THRUST WASHER
29	532 42 71-47	IMPELLER SHAFT
30	532 00 78-36	ROLL PIN
31	532 17 46-81	THRUST WASHER
32	532 17 46-84	THRUST BEARING
33	532 40 77-69	BEARING
34	532 40 77-68	O-RING
35	532 40 77-67	SCREW 5/16-18 X .750
36	532 42 73-17	GEARBOX COVER LH
37	532 19 20-90	SHEAR BOLTS

NOTE: All component dimensions given in U.S. inches. 1 inch = 25.4 mm

IMPORTANT: Use only Original Equipment Manufacturer (O.E.M.) replacement parts. Failure to do so could be hazardous, damage your snow thrower and void your warranty.

REPAIR PARTS

AUGER HOUSING / IMPELLER ASSEMBLY

SNOW THROWER - MODEL NO. **PSB240** (96191003500), PRODUCT NO. 961 91 00 35

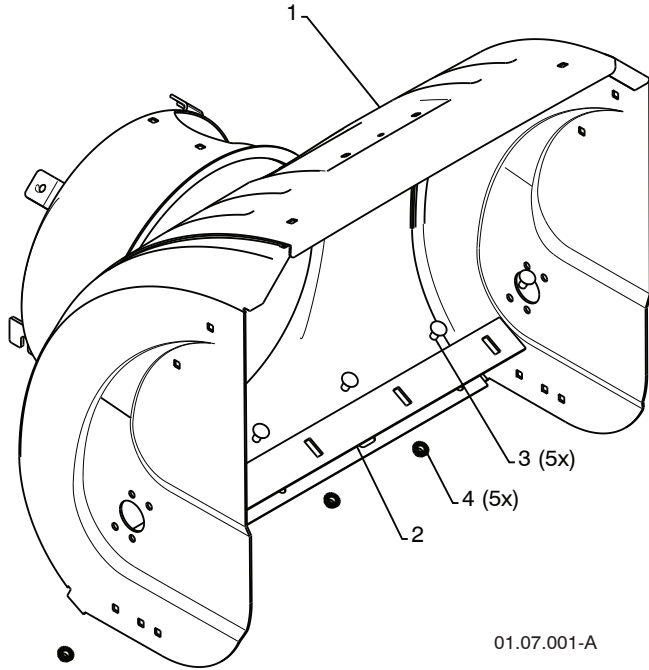

01.07.001-A

KEY NO.	PART NO.	DESCRIPTION
1	532 41 52-95	AUGER HOUSING
2	532 41 62-15	SCRAPPER BAR
3	872 27 05-05	CARRIAGEBOLT 5/16-18X.625
4	532 15 53-77	NUT 5/16-18

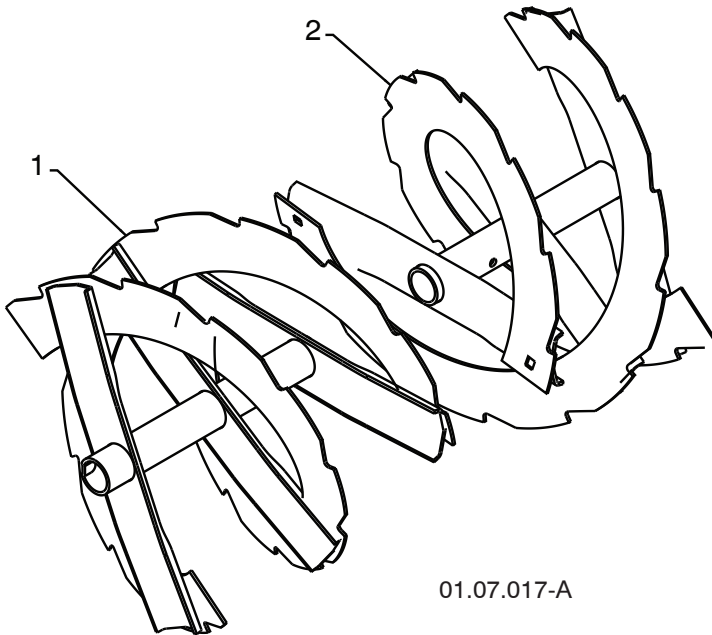

01.07.017-A

KEY NO.	PART NO.	DESCRIPTION
1	532 42 10-72	AUGER ASSEMBLY 30 LH
2	532 42 10-73	AUGER ASSEMBLY 30 RH

NOTE: All component dimensions given in U.S. inches. 1 inch = 25.4 mm
IMPORTANT: Use only Original Equipment Manufacturer (O.E.M.) replacement parts.
 Failure to do so could be hazardous, damage your snow thrower and void your warranty.

REPAIR PARTS

AUGER HOUSING / IMPELLER ASSEMBLY

SNOW THROWER - MODEL NO. **PSB240** (96191003500), PRODUCT NO. 961 91 00 35

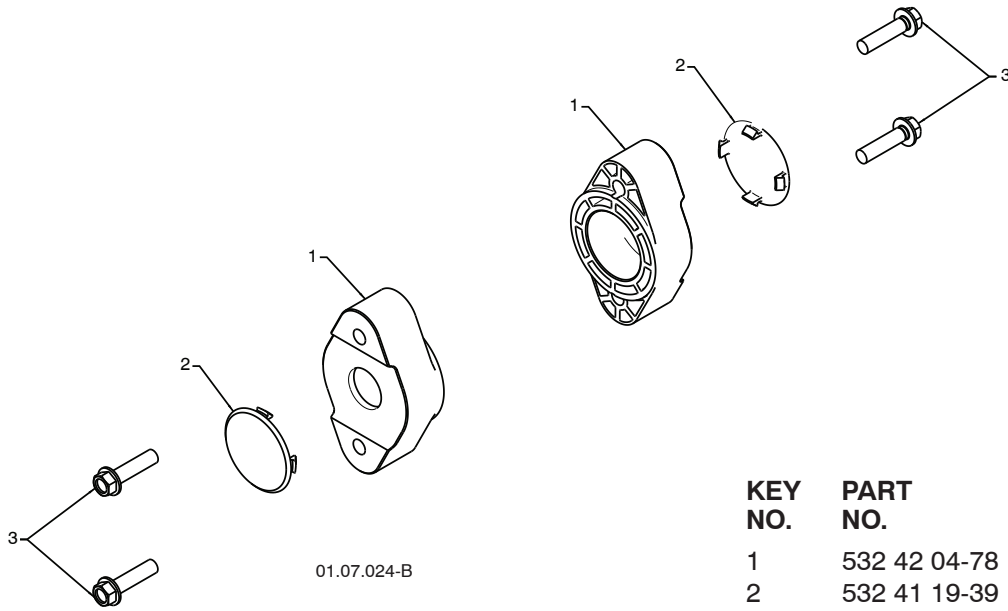

KEY NO.	PART NO.	DESCRIPTION
1	532 42 04-78	AUGER BEARING
2	532 41 19-39	BEARING PLUG
3	532 17 95-82	SCREW 5/16-18 X 1.00

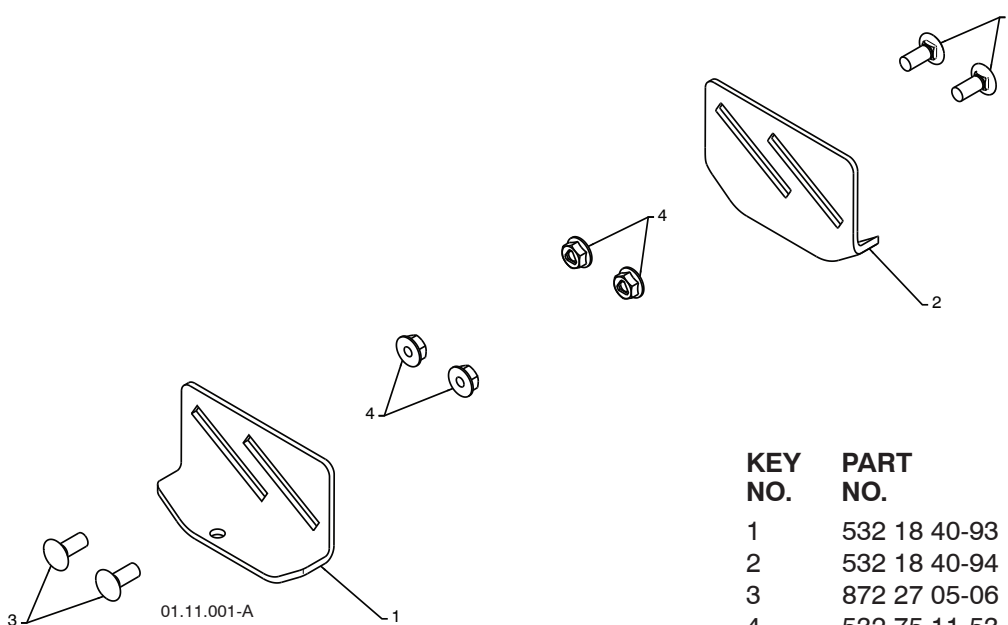

KEY NO.	PART NO.	DESCRIPTION
1	532 18 40-93	SKID PLATE LH
2	532 18 40-94	SKID PLATE RH
3	872 27 05-06	CARRIAGE BOLT 5/16-18 X .75
4	532 75 11-53	NUT 5/16-18

NOTE: All component dimensions given in U.S. inches. 1 inch = 25.4 mm
IMPORTANT: Use only Original Equipment Manufacturer (O.E.M.) replacement parts.
 Failure to do so could be hazardous, damage your snow thrower and void your warranty.

REPAIR PARTS

CONTROL PANEL / DISCHARGE CHUTE

SNOW THROWER - MODEL NO. **PSB240** (96191003500), PRODUCT NO. 961 91 00 35

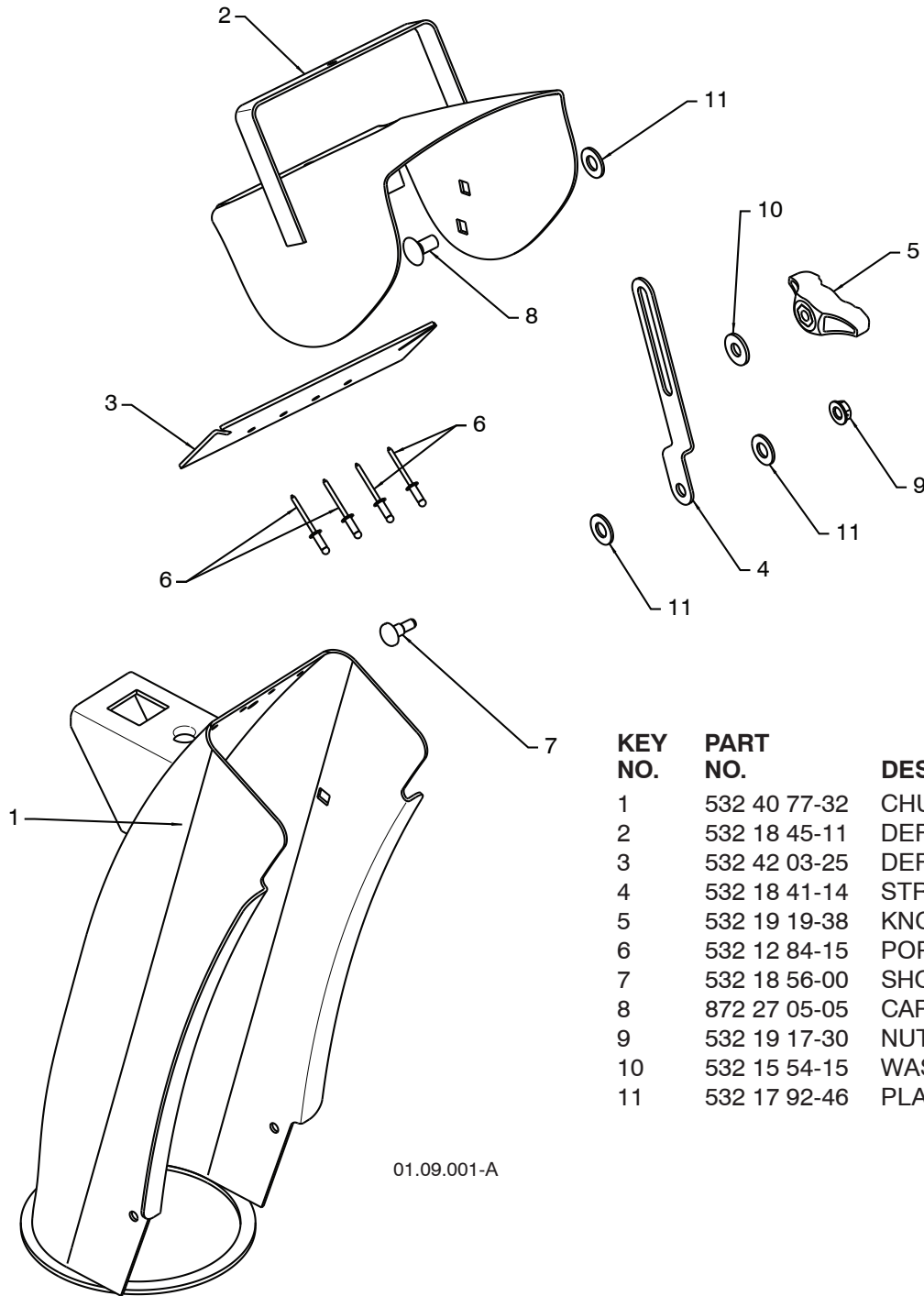

KEY NO.	PART NO.	DESCRIPTION
1	532 40 77-32	CHUTE WELDMENT
2	532 18 45-11	DEFLECTOR WELDMENT
3	532 42 03-25	DEFLECTOR SEAL
4	532 18 41-14	STRAP
5	532 19 19-38	KNOB BLACK
6	532 12 84-15	POP RIVET
7	532 18 56-00	SHOULDER BOLT 1/4-20 X .704
8	872 27 05-05	CARRIAGE BOLT 5/16-18 X .625
9	532 19 17-30	NUT 1/4-20
10	532 15 54-15	WASHER
11	532 17 92-46	PLASTIC WASHER

01.09.001-A

NOTE: All component dimensions given in U.S. inches. 1 inch = 25.4 mm
IMPORTANT: Use only Original Equipment Manufacturer (O.E.M.) replacement parts.
 Failure to do so could be hazardous, damage your snow thrower and void your warranty.

REPAIR PARTS

CONTROL PANEL / DISCHARGE CHUTE

SNOW THROWER - MODEL NO. **PSB240** (96191003500), PRODUCT NO. 961 91 00 35

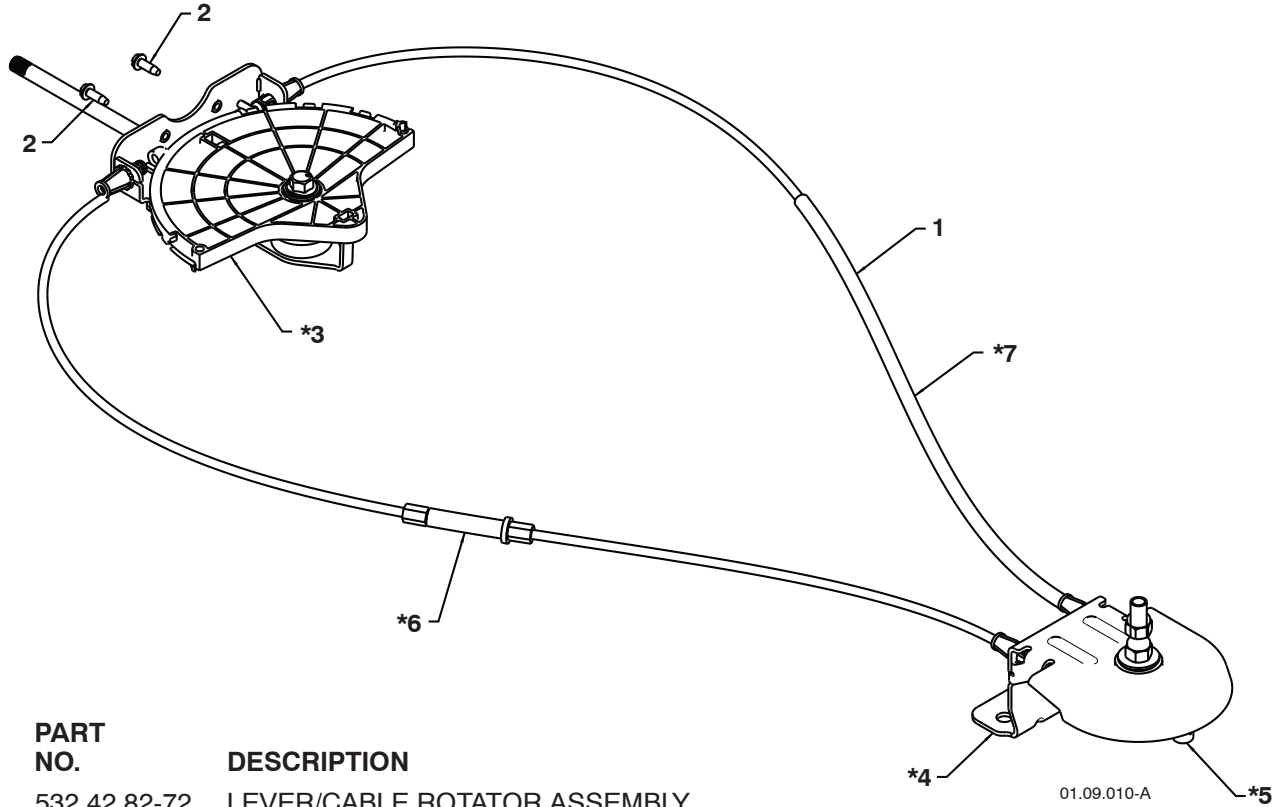

KEY NO.	PART NO.	DESCRIPTION
1	532 42 82-72	LEVER/CABLE ROTATOR ASSEMBLY
2	817 50 10-10	SCREW 10-24 X .625
*3	532 42 06-78	ROTATOR HEAD
*4	532 40 59-32	ROTATOR PIVOT BRACKET
*5	532 42 06-75	PULLEY PIVOT
*6	532 42 82-73	CABLE ASSEMBLY ADJUSTABLE
*7	532 42 83-10	CABLE ASSEMBLY HEAT SHIELD

NOTES:

1. ITEMS INDICATED WITH AN * ARE LISTED AS REFERENCE FOR SERVICE PARTS ONLY.

REPAIR PARTS

HANDLES

SNOW THROWER - MODEL NO. **PSB240** (96191003500), PRODUCT NO. 961 91 00 35

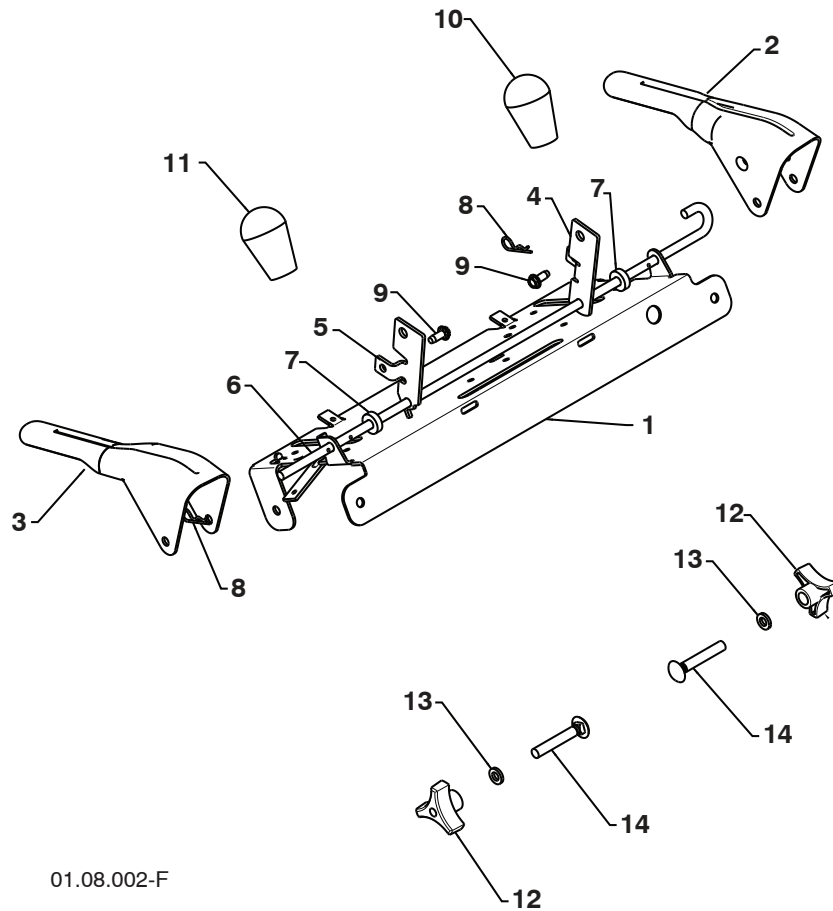

01.08.002-F

KEY NO.	PART NO.	DESCRIPTION
1	532 41 55-39	CONTROL PANEL
2	532 42 88-59	CONTROL LEVER LH
3	532 42 88-60	CONTROL LEVER RH
4	532 42 90-97	TRACTION ROD ARM
5	532 42 90-98	IMPELLER ROD ARM
6	532 41 26-77	INTERLOCK ROD
7	532 42 16-13	SPACER
8	532 16 96-75	RETAINER
9	817 06 04-10	SCREW 1/4-20 X .62
10	532 41 42-80	KNOB BLACK
11	532 41 42-81	KNOB RED
12	532 17 88-99	HANDLE KNOB
13	819 13 13-16	WASHER 3/8
14	872 12 06-18	CARRIAGE BOLT 3/8-16 X 2.25

NOTE: All component dimensions given in U.S. inches. 1 inch = 25.4 mm
IMPORTANT: Use only Original Equipment Manufacturer (O.E.M.) replacement parts. Failure to do so could be hazardous, damage your snow thrower and void your warranty.

REPAIR PARTS

HANDLES

SNOW THROWER - MODEL NO. **PSB240** (96191003500), PRODUCT NO. 961 91 00 35

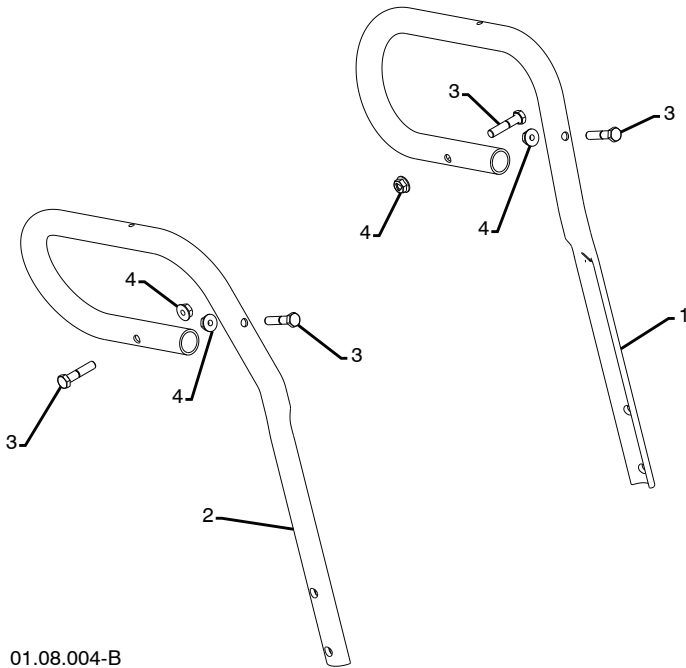

01.08.004-B

KEY NO.	PART NO.	DESCRIPTION
1	532 42 11-20	LOOP HANDLE LH
2	532 42 11-21	LOOP HANDLE RH
3	874 78 05-24	SCREW 5/16-18 X 1.50
4	532 75 11-53	NUT 5/16-18

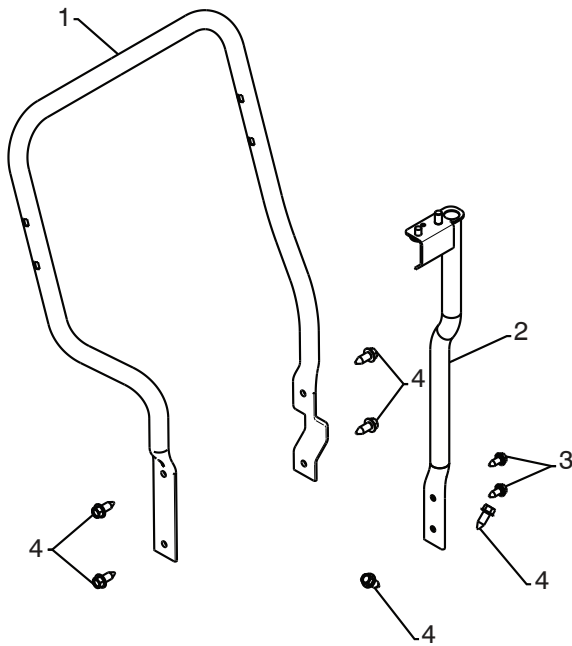

01.05.003-C

KEY NO.	PART NO.	DESCRIPTION
1	532 42 10-59	LOWER TUBE
2	532 42 21-17	PIVOT SUPPORT
3	532 42 88-67	BOLT 5/16-18 X .750
4	817 00 06-16	SCREW 3/8-16 X 1 .00

NOTE: All component dimensions given in U.S. inches. 1 inch = 25.4 mm
IMPORTANT: Use only Original Equipment Manufacturer (O.E.M.) replacement parts.
 Failure to do so could be hazardous, damage your snow thrower and void your warranty.

REPAIR PARTS

HANDLES

SNOW THROWER - MODEL NO. **PSB240** (96191003500), PRODUCT NO. 961 91 00 35

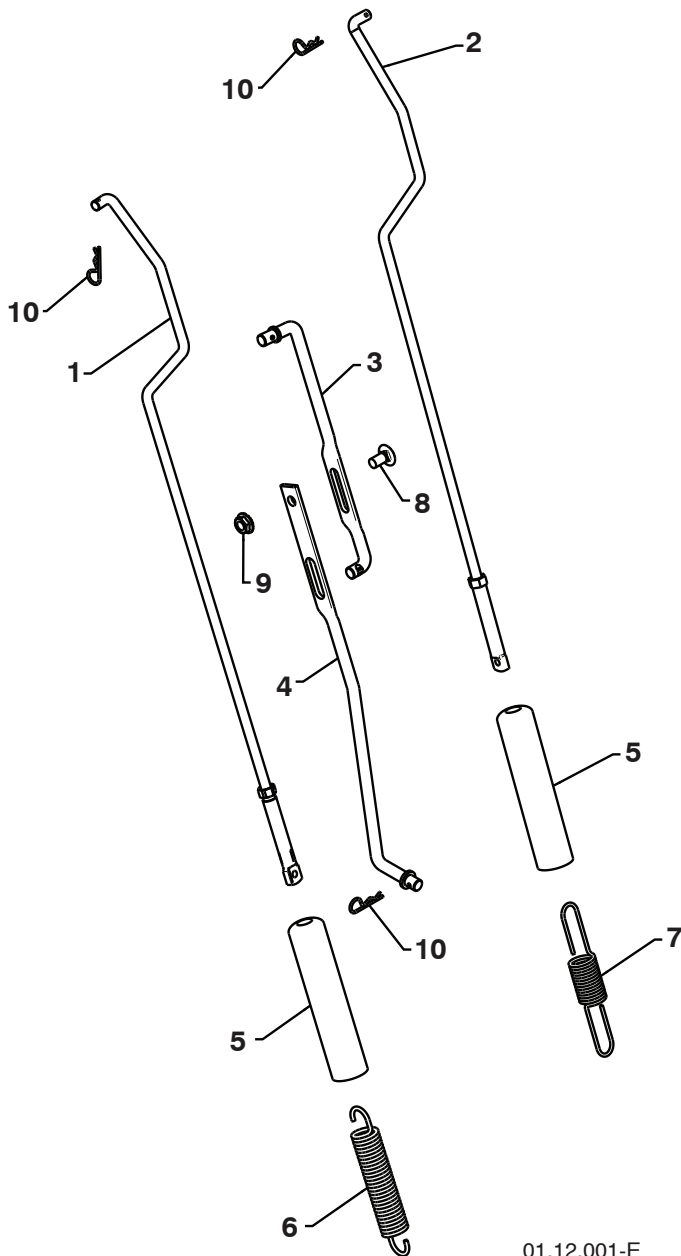

KEY NO.	PART NO.	DESCRIPTION
1	532 18 04-80	IMPELLER ROD ASSEMBLY
2	532 40 57-40	TRACTION ROD ASSEMBLY
3	532 18 04-45	SHIFTER ROD TOP
4	532 18 77-16	SHIFTER ROD BOTTOM
5	532 18 04-47	SPRING SLEEVE
6	532 17 86-69	IMPELLER SPRING
7	532 18 09-26	TRACTION SPRING
8	872 27 05-05	CARRIAGE BOLT 5/16-18 X .750
9	532 15 53-77	NUT 5/16-18
10	532 16 96-75	RETAINER

01.12.001-E

NOTE: All component dimensions given in U.S. inches. 1 inch = 25.4 mm
IMPORTANT: Use only Original Equipment Manufacturer (O.E.M.) replacement parts.
Failure to do so could be hazardous, damage your snow thrower and void your warranty.

REPAIR PARTS

HANDLES

SNOW THROWER - MODEL NO. **PSB240** (96191003500), PRODUCT NO. 961 91 00 35

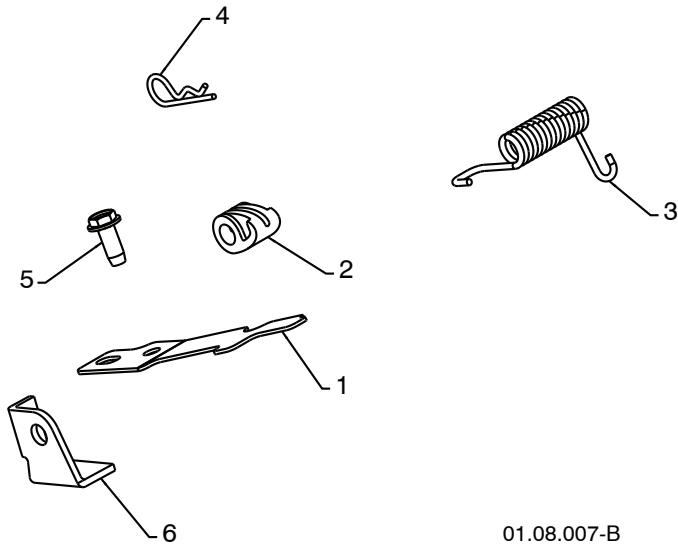

KEY NO.	PART NO.	DESCRIPTION
1	532 41 62-88	INTERLOCK SPRING
2	532 41 45-72	INTERLOCK CAM
3	532 17 88-31	TORSION SPRING
4	532 16 96-75	RETAINER
5	817 06 04-10	SCREW 1/4-20 X .625
6	532 42 18-14	INTERLOCK STOP

01.08.007-B

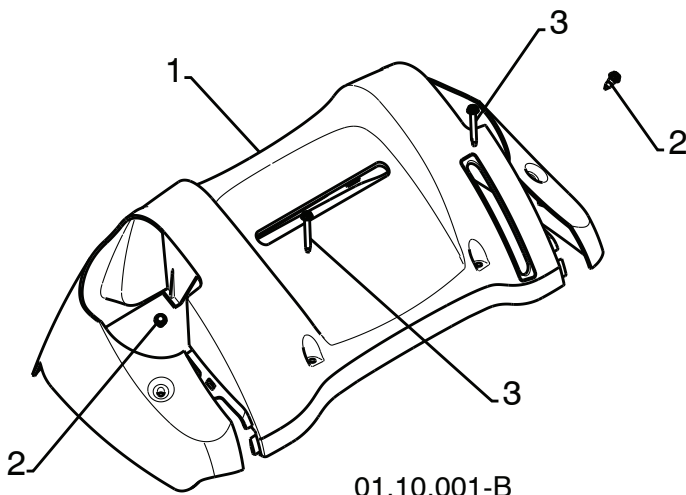

KEY NO.	PART NO.	DESCRIPTION
1	532 18 33-52	CONSOLE PANEL
2	532 18 44-71	SCREW 10-24 X .625
3	532 17 52-62	SCREW 10-24 X 1.25

01.10.001-B

NOTE: All component dimensions given in U.S. inches. 1 inch = 25.4 mm
IMPORTANT: Use only Original Equipment Manufacturer (O.E.M.) replacement parts.
 Failure to do so could be hazardous, damage your snow thrower and void your warranty.

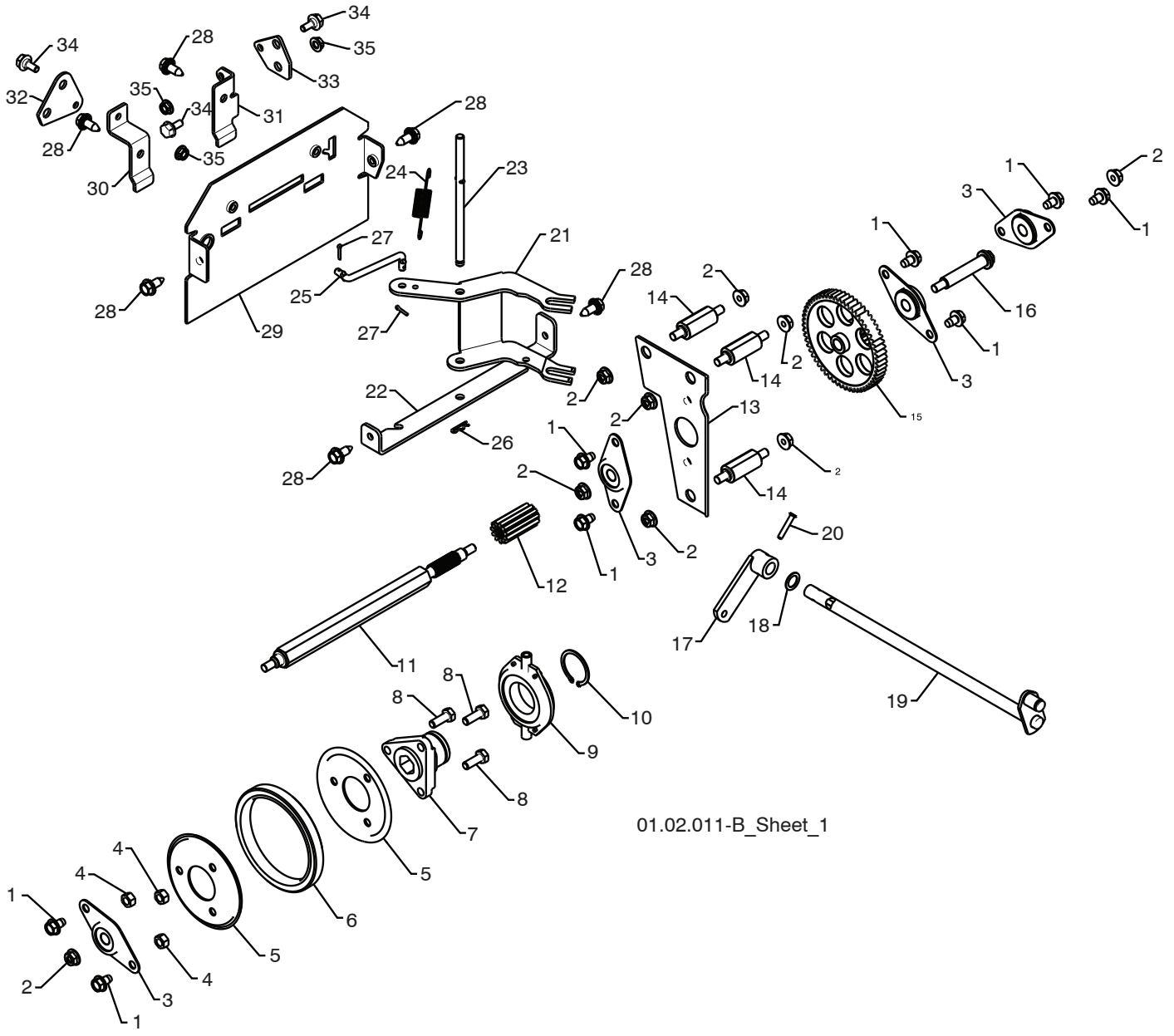

01.02.011-B_Sheet_1

NOTE: All component dimensions given in U.S. inches. 1 inch = 25.4 mm
IMPORTANT: Use only Original Equipment Manufacturer (O.E.M.) replacement parts.
Failure to do so could be hazardous, damage your snow thrower and void your warranty.

REPAIR PARTS**DRIVE****SNOW THROWER - MODEL NO. PSB240 (96191003500), PRODUCT NO. 961 91 00 35**

KEY NO.	PART NO.	DESCRIPTION
1	817 49 05-08	BOLT 5/16-18 X .500
2	532 75 11-53	NUT 5/16-18
3	532 18 00-17	FLANGE BEARING
4	873 93 05-00	NUT 5/16-18
5	532 19 95-09	RUBBER WHEEL PLATE
6	532 17 98-31	RUBBER WHEEL RING
7	532 17 86-13	RUBBER WHEEL HUB
8	874 76 05-14	BOLT 5/16-18 X .875
9	532 17 53-44	TRUNNION BEARING ASSEMBLY
10	812 00 00-12	RETAINER
11	532 18 00-66	HEX SHAFT
12	532 18 00-65	PINION GEAR
13	532 19 29-07	AUXILIARY PLATE
14	532 17 92-70	SPACER PLATE
15	532 18 00-82	INTERMEDIATE GEAR
16	532 18 01-34	AUXILIARY SHAFT
17	532 40 54-85	CONTROL ARM
18	532 05 70-79	WASHER
19	532 42 75-42	CONTROL SHAFT ASSEMBLY
20	532 19 85-80	CLEVIS PIN
21	532 18 40-80	SHIFTER LEVER
22	532 18 78-57	PIVOT BRACKET
23	532 17 88-07	PIVOT PIN
24	532 18 01-35	SPRING
25	532 18 71-01	SHIFTER LINK
26	532 08 51-79	RETAINER
27	532 70 02-79	CLIP
28	532 42 88-67	SCREW 5/16-18 x .750
29	532 41 67-50	REAR PLATE
30	532 41 54-33	SHIFTER PLATE BRACKET
31	532 41 68-64	CLUTCH PLATE BRACKET
32	532 41 54-50	SHIFTER PLATE
33	532 41 54-35	CLUTCH PLATE
34	532 40 28-81	SHOULDER BOLT 1/4-20 X .500
35	532 19 17-30	NUT 1/4-20

NOTE: All component dimensions given in U.S. inches. 1 inch = 25.4 mm

IMPORTANT: Use only Original Equipment Manufacturer (O.E.M.) replacement parts. Failure to do so could be hazardous, damage your snow thrower and void your warranty.

REPAIR PARTS

DRIVE

SNOW THROWER - MODEL NO. **PSB240** (96191003500), PRODUCT NO. 961 91 00 35

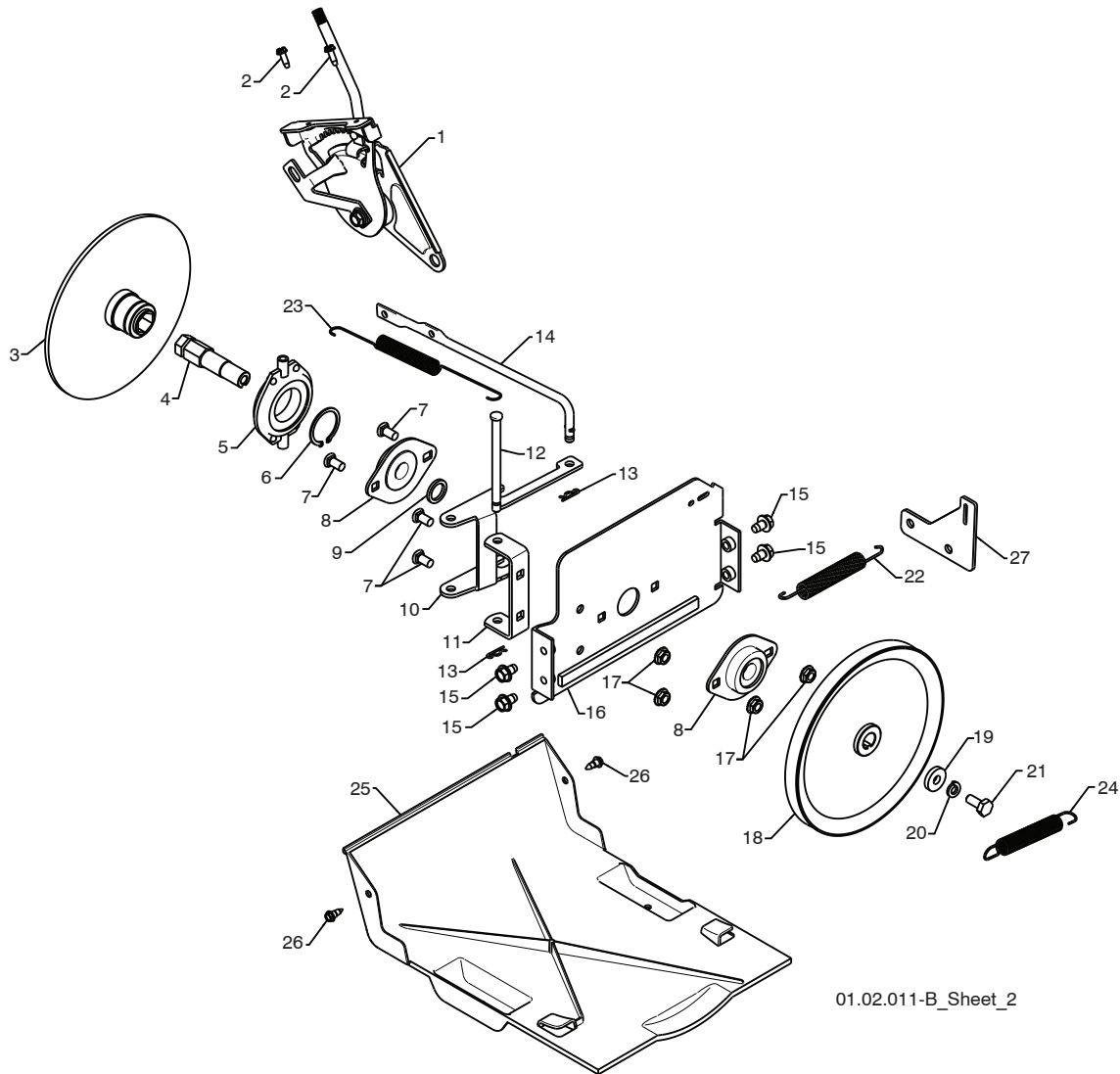

01.02.011-B_Sheet_2

KEY NO.	PART NO.	DESCRIPTION	KEY NO.	PART NO.	DESCRIPTION
1	532 19 88-75	SPEED SELECTOR HEAD ASSEMBLY	13	532 08 51-79	RETAINER
2	817 50 10-10	SCREW 10-24 X .625	14	532 40 33-00	CLUTCH ROD
3	532 19 77-63	DRIVE PLATE WELDMENT	15	817 49 05-08	BOLT 5/16-18 X .500
4	532 19 77-64	HEX SHAFT	16	532 18 40-75	DRIVE MOUNT PLATE
5	532 17 53-44	TRUNNION BEARING ASSEMBLY	17	532 15 53-77	NUT 5/16-18
6	812 00 00-12	RETAINER	18	532 19 10-80	TRACTION PULLEY
7	872 27 05-05	CARRIAGE BOLT 5/16-18 X .625	19	819 11 15-07	WASHER
8	532 18 89-09	FLANGE BEARING	20	810 04 05-00	LOCKWASHER 5/16
9	532 18 25-04	SPACER	21	874 95 05-12	SCREW 5/16-18 X .750
10	532 18 40-77	LEVER SHIFTER PLATE	22	532 41 45-57	TRACTION SPRING
11	532 18 40-76	SHIFTER SUPPORT BRACKET	23	532 17 90-95	RETURN SPRING
12	532 17 86-95	PIN	24	532 17 88-28	BRAKE SPRING
			25	532 41 08-77	BOTTOM PAN
			26	532 18 44-71	SCREW 10-24 X .625
			27	532 41 66-82	TRACTION SPRING BRACKET

NOTE: All component dimensions given in U.S. inches. 1 inch = 25.4 mm
IMPORTANT: Use only Original Equipment Manufacturer (O.E.M.) replacement parts.
 Failure to do so could be hazardous, damage your snow thrower and void your warranty.

REPAIR PARTS

DRIVE

SNOW THROWER - MODEL NO. **PSB240** (96191003500), PRODUCT NO. 961 91 00 35

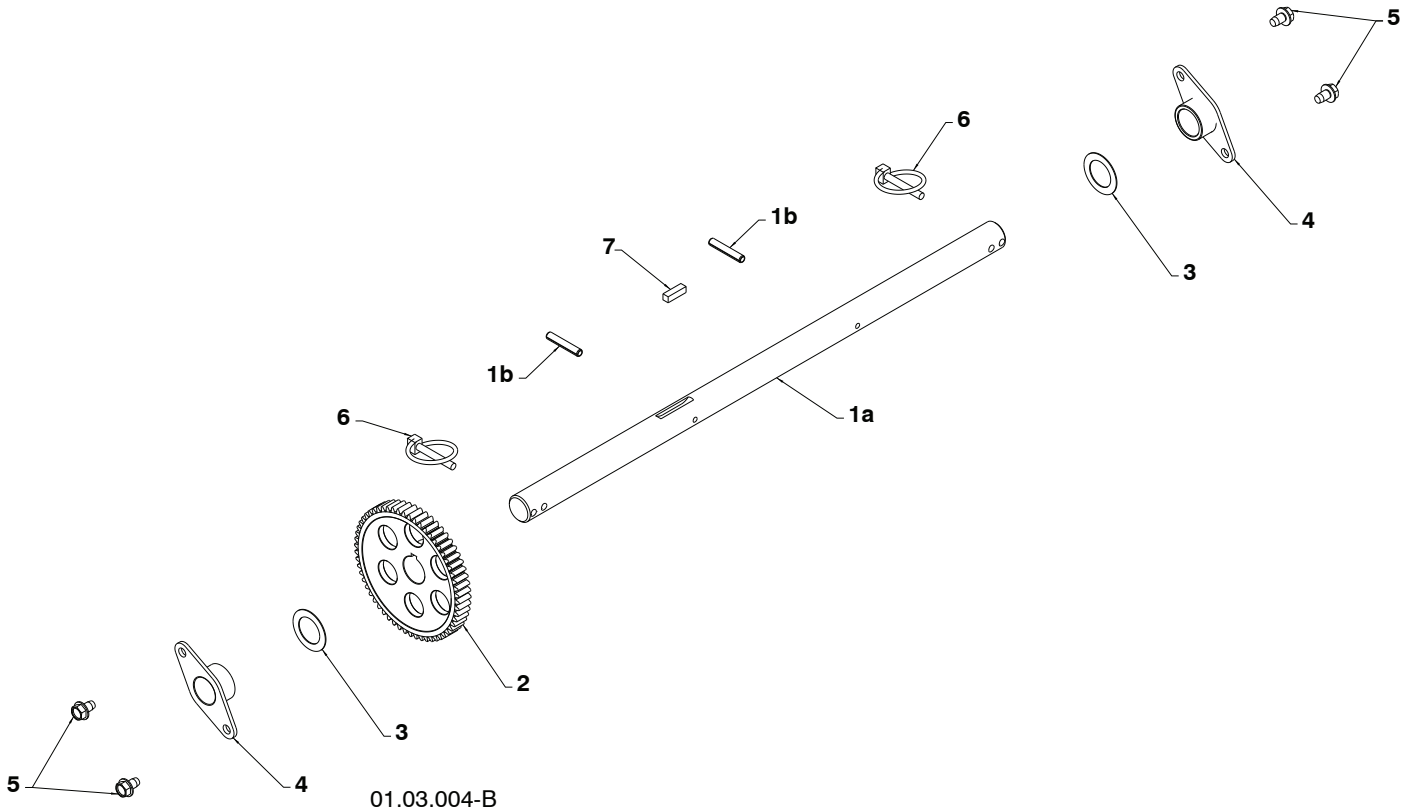

KEY NO.	PART NO.	DESCRIPTION
1	532 18 82-26	(assy of 1a,1b) AXLE ASSEMBLY
1a	532 17 93-52	AXLE SHAFT
1b	532 18 42-06	ROLL PIN 3/16
2	532 18 00-81	GEAR
3	532 17 46-97	THRUST WASHER
4	532 17 98-30	BEARING
5	817 49 05-08	BOLT 5/16-18 X .500
6	532 15 54-43	CLIK PIN
7	532 18 92-82	SQUARE KEY

NOTE: All component dimensions given in U.S. inches. 1 inch = 25.4 mm
IMPORTANT: Use only Original Equipment Manufacturer (O.E.M.) replacement parts.
 Failure to do so could be hazardous, damage your snow thrower and void your warranty.

REPAIR PARTS

CHASSIS / PULLEYS

SNOW THROWER - MODEL NO. **PSB240** (96191003500), PRODUCT NO. 961 91 00 35

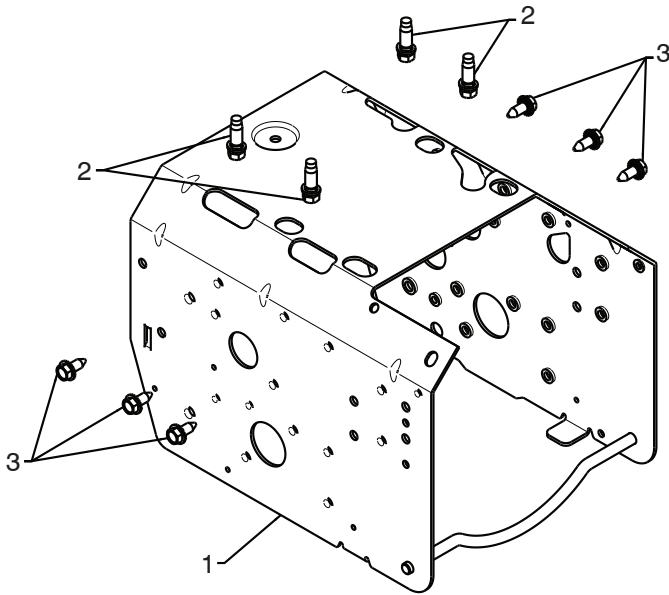

01.00.033-A

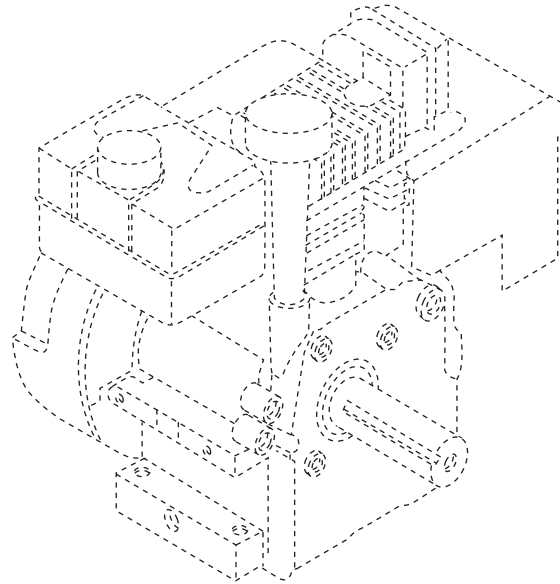

KEY NO.	PART NO.	DESCRIPTION
--	-----	B&S ENGINE MODEL 12A112-0921-E8
1	532 42 92-80	FRAME
2	532 15 04-06	BOLT 3/8-16
3	532 42 88-67	SCREW 5/16-18 X .750

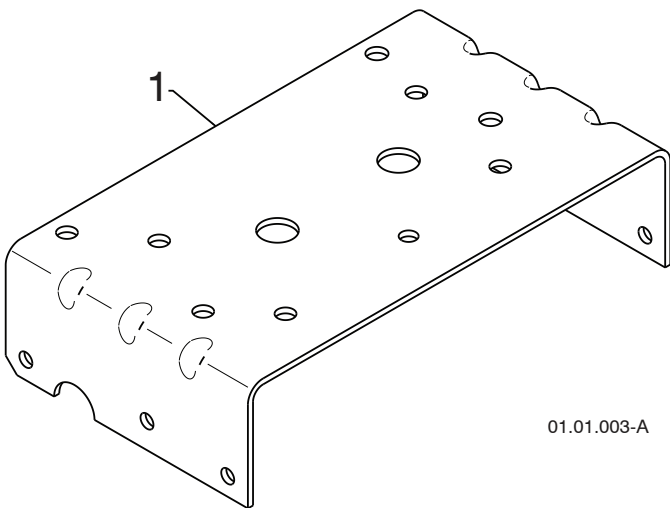

01.01.003-A

KEY NO.	PART NO.	DESCRIPTION
1	532 42 38-71	ENGINE MOUNTING PLATE

NOTE: All component dimensions given in U.S. inches. 1 inch = 25.4 mm
IMPORTANT: Use only Original Equipment Manufacturer (O.E.M.) replacement parts.
 Failure to do so could be hazardous, damage your snow thrower and void your warranty.

REPAIR PARTS

CHASSIS / PULLEYS

SNOW THROWER - MODEL NO. **PSB240** (96191003500), PRODUCT NO. 961 91 00 35

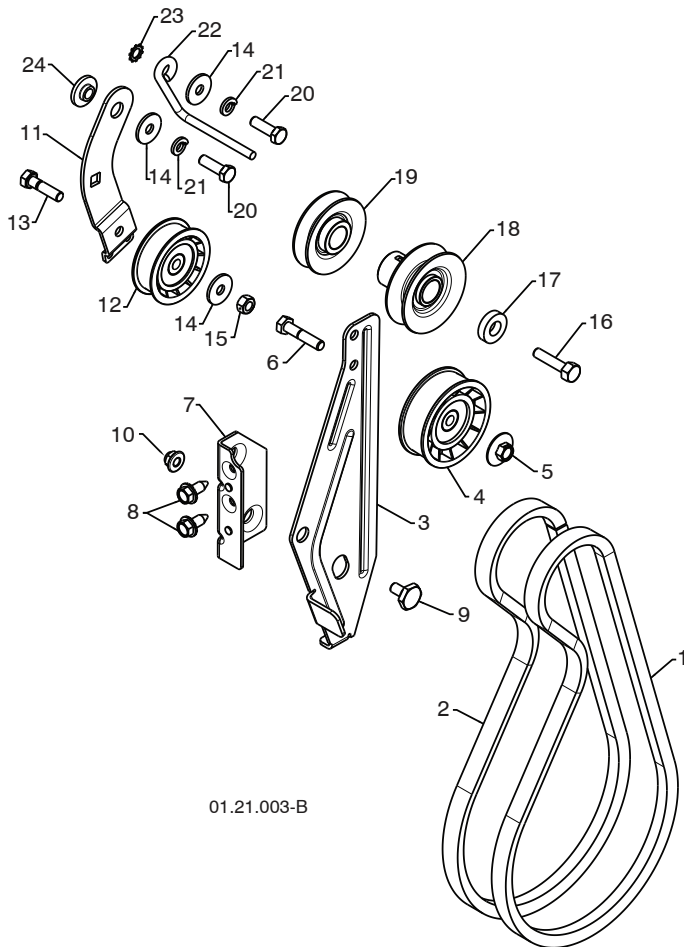

01.21.003-B

KEY NO.	PART NO.	DESCRIPTION
1	532 40 80-07	IMPELLER BELT
2	532 41 97-44	TRACTION BELT
3	532 42 37-23	IDLER ARM BRACKET
4	532 18 05-23	IDLER PULLEY
5	532 42 65-89	NUT 5/16-18
6	874 78 05-24	SCREW 5/16-18 X 1 .50
7	532 42 39-90	IDLER BRACKET
8	532 42 88-67	SCREW 5/16-18 X .625
9	532 42 42-97	SHOULDERBOLT 5/16-18 X .500
10	532 75 11-53	NUT 5/16-18 NYLOCK
11	532 18 77-86	TRACTION IDLER ARM
12	532 18 05-22	TRACTION PULLEY
13	874 78 05-20	SCREW 5/16-18 X 1 .00
14	532 05 92-89	WASHER
15	873 80 05-00	NUT 5/16-18
16	532 85 10-84	SCREW 3/8-24 X 1.375
17	532 40 00-26	WASHER
18	532 42 64-91	PULLEY ENG IMPELLER
19	532 42 64-90	PULLEY ENG TRACTION
20	874 61 05-16	SCREW 5/16-18 X 1 .00
21	810 04 05-00	LOCKWASHER 5/16
22	532 15 54-52	BELT GUIDE
23	811 05 05-00	LOCKWASHER 5/16
24	532 17 53-31	IDLER BUSHING

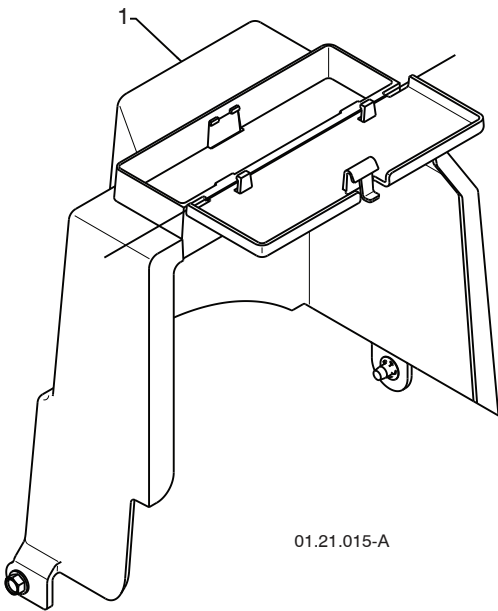

01.21.015-A

KEY NO.	PART NO.	DESCRIPTION
1	532 42 86-84	COVER ASSEMBLY

NOTE: All component dimensions given in U.S. inches. 1 inch = 25.4 mm
IMPORTANT: Use only Original Equipment Manufacturer (O.E.M.) replacement parts.
 Failure to do so could be hazardous, damage your snow thrower and void your warranty.

REPAIR PARTS

WHEELS

SNOW THROWER - MODEL NO. **PSB240** (96191003500), PRODUCT NO. 961 91 00 35

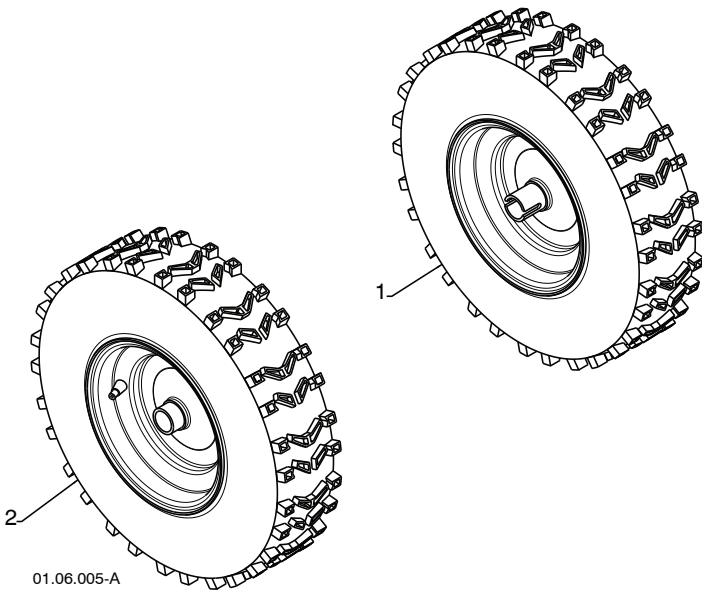

KEY NO.	PART NO.	DESCRIPTION
1	532 41 52-93	WHEEL 16 X 4.80 X LH
2	532 41 53-36	WHEEL 16 X 4.80 X RH

NOTE: All component dimensions given in U.S. inches. 1 inch = 25.4 mm
IMPORTANT: Use only Original Equipment Manufacturer (O.E.M.) replacement parts.
Failure to do so could be hazardous, damage your snow thrower and void your warranty.

REPAIR PARTS

BAG OF PARTS

SNOW THROWER - MODEL NO. **PSB240** (96191003500), PRODUCT NO. 961 91 00 35

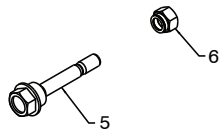
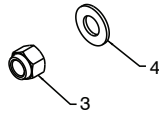
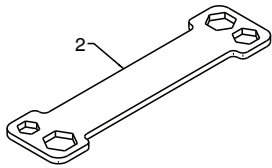

01.14.006-B

KEY NO.	PART NO.	DESCRIPTION
1	532 16 96-75	RETAINER PIN
2	532 42 91-12	WRENCH
3	873 80 06-00	LOCKNUT 3/8-16
4	819 13 13-16	WASHER 3/8
5	532 19 20-90	SHEAR BOLT 1/4-20 X 1-13/16
6	873 80 04-00	LOCKNUT 1/4-20

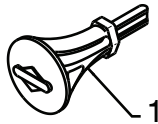

01.14.007-A

KEY NO.	PART NO.	DESCRIPTION
1	532 19 30-71	SAFETY IGNITION KEY

NOTE: All component dimensions given in U.S. inches. 1 inch = 25.4 mm
IMPORTANT: Use only Original Equipment Manufacturer (O.E.M.) replacement parts.
 Failure to do so could be hazardous, damage your snow thrower and void your warranty.

REPAIR PARTS

DECALS

SNOW THROWER - MODEL NO. **PSB240** (96191003500), PRODUCT NO. 961 91 00 35

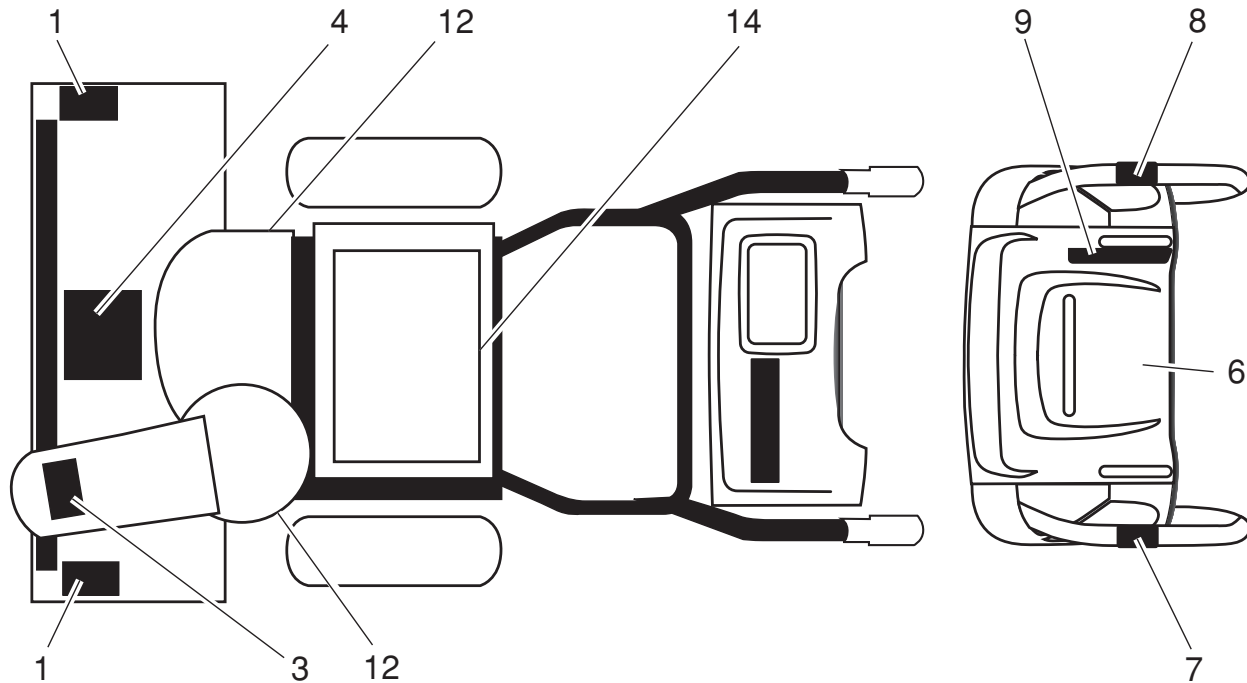

KEY NO.	PART NO.	DESCRIPTION
1	532 19 96-83	DECAL, DANGER
3	532 19 96-82	DECAL, DANGER, DEFLECTOR
4	532 18 40-45	DECAL, DANGER
6	532 18 40-30	DECAL, INSTRUCTION
7	532 41 53-93	DECAL, TRACTION LEVER
8	532 41 53-92	DECAL, AUGER LEVER
9	532 41 54-77	DECAL, SPEED CONTROL
12	532 18 40-28	DECAL, BELT GUARD
14	532 18 04-33	DECAL, SOUND LEVEL
--	532 42 86-50	REPAIR PARTS MANUAL
--	532 42 86-45	OPERATOR'S MANUAL, EURO
--	532 42 86-46	OPERATOR'S MANUAL, SCAND
--	532 42 86-47	OPERATOR'S MANUAL, EAST BLOC
--	532 42 86-48	OPERATOR'S MANUAL, BALTIC

NOTE: All component dimensions given in U.S. inches. 1 inch = 25.4 mm

IMPORTANT: Use only Original Equipment Manufacturer (O.E.M.) replacement parts. Failure to do so could be hazardous, damage your snow thrower and void your warranty.